



# PUBLIC ADDRESS SYSTEM

# OPERATION MANUAL

T-4060MP  
T-4120MP  
T-4240MP

4 ZONE MIXER AMPLIFIER

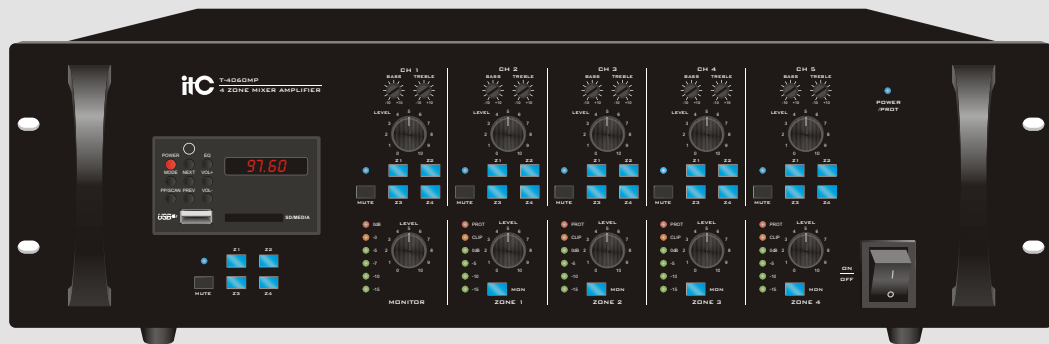

Please follow the instructions in this manual to obtain the optimum results from this unit.  
We also recommend that you keep this manual handy for future reference.

## TABLE OF CONTENTS

1. SAFETY PRECAUTIONS .....	3
2. FEATURES .....	5
3. NOMENCLATURE AND FUNCTIONS	
3.1 Front Panel .....	6
3.2 Rear Panel .....	7
4. OPERATION.....	8
5. Mute function.....	9
6. CONNECTIONS	
6.1 Speaker Connections .....	10
7. TROUBLE SHOOTING.....	10
8. APPLICATIONS .....	11
9. BLOCK DIAGRAM.....	12
10. SPECIFICATIONS .....	13
11. DIMENSIONAL DIAGRAM .....	14

# 1. SAFETY PRECAUTIONS

- Be sure to read the instructions in this section carefully before use.
- Make sure to observe the instructions in this manual as the conventions of safety symbols and messages regarded as very important precautions are included.
- We also recommend you keep this instruction manual handy for future reference.

## Safety Symbol and Message Conventions

Safety symbols and messages described below are used in this manual to prevent bodily injury and property damage which could result from mishandling. Before operating your product, read this manual first and understand the safety symbols and messages so you are thoroughly aware of the potential safety



### WARNING

Indicates a potentially hazardous situation which, if mishandled, could result in death or serious personal injury.



### CAUTION

Indicates a potentially hazardous situation which, if mishandled, could result in moderate or minor personal injury, and/or property damage.



### WARNING

#### When Installing the Unit

- Do not expose the unit to rain or an environment where it may be splashed by water or other liquids, as doing so may result in fire or electric shock.
- Use the unit only with the voltage specified on the unit. Using a voltage higher than that which is specified may result in fire or electric shock.
- Do not cut, kink, otherwise damage nor modify the power supply cord. In addition, avoid using the power cord in close proximity to heaters, and never place heavy objects -- including the unit itself -- on the power cord, as doing so may result in fire or electric shock.
- Be sure to replace the unit's terminal cover after connection completion. Because high voltage is applied to the speaker terminals, never touch these terminals to avoid electric shock.
- Be sure to ground to the safety ground (earth) terminal to avoid electric shock. Never ground to a gas pipe as a catastrophic disaster may result.
- Avoid installing or mounting the unit in unstable locations, such as on a rickety table or a slanted surface. Doing so may result in the unit falling down, causing personal injury and/or property damage.

#### When the Unit is in Use

- Should the following irregularity be found during use, immediately switch off the power, disconnect the power supply plug from the AC outlet and contact your nearest ITC dealer. Make no further attempt to operate the unit in this condition as this may cause fire or electric shock.
  - If you detect smoke or a strange smell coming from the unit.
  - If water or any metallic object gets into the unit
  - If the unit falls, or the unit case breaks
  - If the power supply cord is damaged (exposure of the core, disconnection, etc.)
  - If it is malfunctioning (no tone sounds.)
- To prevent a fire or electric shock, never open nor remove the unit case as there are high voltage components inside the unit. Refer all servicing to your nearest ITC dealer.
- Do not place cups, bowls, or other containers of liquid or metallic objects on top of the unit. If they accidentally spill into the unit, this may cause a fire or electric shock.
- Do not insert nor drop metallic objects or flammable materials in the ventilation slots of the unit's cover, as this may result in fire or electric shock.

### CAUTION

#### When Installing the Unit

- Never plug in nor remove the power supply plug with wet hands, as doing so may cause electric shock.
- When unplugging the power supply cord, be sure to grasp the power supply plug; never pull on the cord itself. Operating the unit with a damaged power supply cord may cause a fire or electric shock.
- When moving the unit, be sure to remove its power supply cord from the wall outlet. Moving the unit with the power cord connected to the outlet may cause damage to the power cord, resulting in fire or electric shock. When removing the power cord, be sure to hold its plug to pull.
- Do not block the ventilation slots in the unit's cover. Doing so may cause heat to build up inside the unit and result in fire.
- Avoid installing the unit in humid or dusty locations, in locations exposed to the direct sunlight, near the heaters, or in locations generating sooty smoke or steam as doing otherwise may result in fire or electric shock.

#### When the Unit is in Use

- Do not place heavy objects on the unit as this may cause it to fall or break which may result in personal injury and/or property damage. In addition, the object itself may fall off and cause injury and/or damage.
- Make sure that the volume control is set to minimum position before power is switched on. Loud noise produced at high volume when power is switched on can impair hearing.
- Do not operate the unit for an extended period of time with the sound distorting. This is an indication of a malfunction, which in turn can cause heat to generate and result in a fire.
- Contact your ITC dealer as to the cleaning. If dust is allowed to accumulate in the unit over a long period of time, a fire or damage to the unit may result.
- If dust accumulates on the power supply plug or in the wall AC outlet, a fire may result. Clean it periodically. In addition, insert the plug in the wall outlet securely.
- Switch off the power, and unplug the power supply plug from the AC outlet for safety purposes when cleaning or leaving the unit unused for 10 days or more. Doing otherwise may cause a fire or electric shock.

An all-pole mains switch with a contact separation of at least 3 mm in each pole shall be incorporated in the electrical installation of the building.

## 2. FEATURES

1. Four channel amplifier in a 3U 19 rack mount design.
2. All source inputs could be matrix assigned to different 4 zones outputs simultaneously.
3. The 5 channel inputs & MP3 input are designed with separate bass, treble and volume control.
4. Three microphone / line inputs with phantom power and gain control.
5. Two aux inputs by RAC with gain control.
6. MP3 player with SD and USB inputs, separate power supplied module.
7. Built in tuner audio source.
8. One 4 zone remote microphone input by RJ45 port.
9. Four channel line inputs and speaker outputs.
10. Versatile speaker outputs for each four channels : 70V, 100V and 4  $\Omega$ .
11. A RS232 serial control port for third party system communication.
12. A priority input to override other inputs (equal to EMC input)..
13. Input priority level from high to low: Before short circuit priority input:  
MIC1 TEL Remote MIC MIC2 = MIC3 = LINE4 = LINE5 = MP3  
After short circuit priority input:  
TEL MIC1 Remote MIC MIC2 = MIC3 = LINE4 = LINE5 = MP3
14. Built-in monitor with volume control.
15. Extensive protection of thermal, short-circuit, clip and overload with indicators.
16. With ground lift switch.

## 3. NOMENCLATURE AND FUNCTIONS

### 3.1 FRONT PANEL

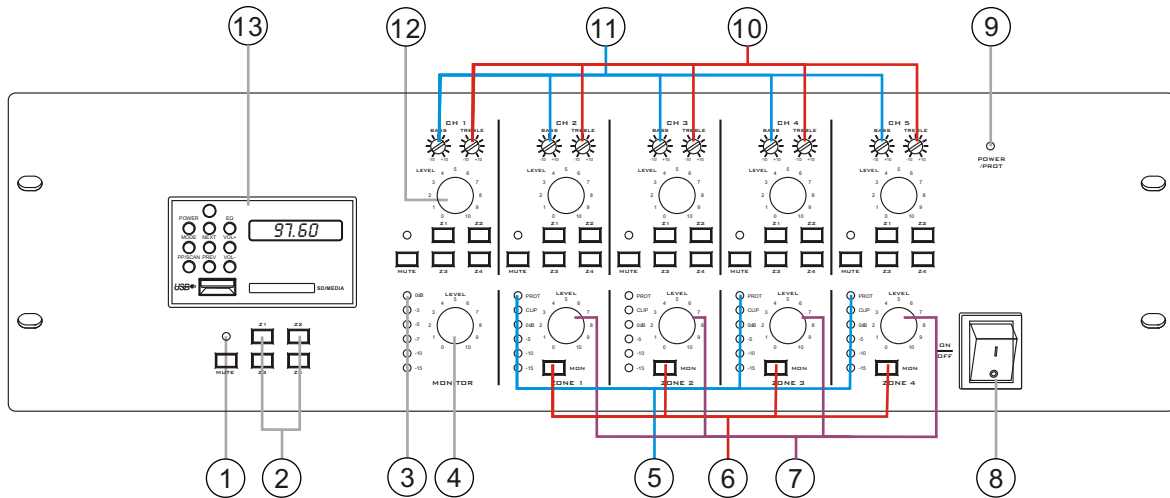

1. Mute button and indicator, mute on, indicators are on; mute off, then indicators are off
2. Amplifier matrix 4 channel selector button
3. Monitor level indicator
4. Monitor volume control  
Adjust monitor volume, clockwise rotation, increase volume, conversely reduce
5. 1-4 zone amplifier level indicator
6. 1-4 zone monitor selector button
7. 1-4 zone amplifier output volume control
8. ON/OFF Power switch  
Switch on, power on, switch down, power off
9. POWER-Power indicator  
When power on, power indicators are on; when power off, power indicators are off
10. CH1-CH4 High-pitched tone control  
Adjust high pitch, clockwise rotation, increase volume, conversely reduce
11. CH1-CH4 low-pitched tone control  
Adjust low pitch, clockwise rotation, increase volume, conversely reduce
12. CH1 volume control
13. Mp3 player, with USB & SD card slot

# NOMENCLATURE AND FUNCTIONS

## 3.2 REAR PANEL

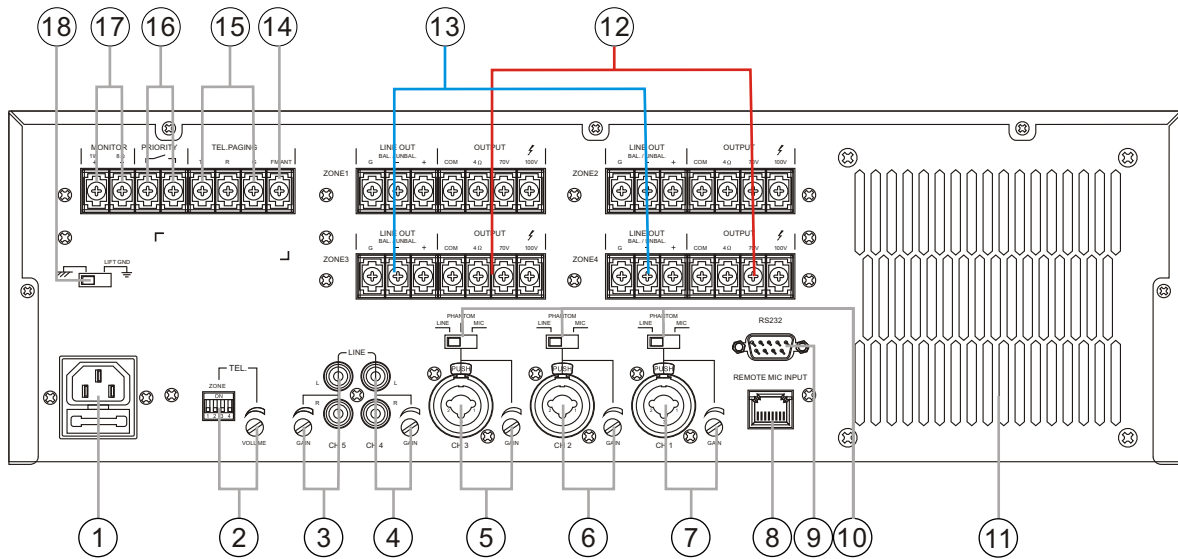

- |  |   |
|--|---|
| <ol style="list-style-type: none"> <li>1. AC power input socket</li> <li>2. Telephone DIP switch and volume control</li> <li>3. CH5 line signal input and signal gain control</li> <li>4. CH4 line signal input and signal gain control</li> <li>5. CH3 microphone signal input and signal gain control</li> <li>6. CH2 microphone signal input and signal gain control</li> <li>7. CH1 microphone signal input and signal gain control</li> <li>8. Remote microphone input port</li> <li>9. RS232 port</li> <li>10. LINE, PHANTOM, MIC signal input selector switch</li> <li>11. vents</li> </ol> | <ol style="list-style-type: none"> <li>12. ZONE1-4 output terminals for connecting speakers; COM is common terminal, can be connected to the negative electrode, the ground, etc. 4Ω terminal can be connected to constant resistance 4Ω speaker; 70V terminal can be connected to 70V constant voltage speaker; 100V terminal can be connected to 100V constant voltage speaker</li> <li>13. ZONE1-4 LINE signal output</li> <li>14. Radio antenna port</li> <li>15. telephone signal input port</li> <li>16. short circuit PRIORITY, can change the priority of Telephone and MIC1</li> <li>17. monitor output port</li> <li>18. Floating switch</li> </ol> |
|--|---|

## 4. OPERATION

### 4.1 Starting -up procedure

- 4.1.1 All "LEVEL" volume knobs set to the "0" position of front panel. "TREBLE" and "BASS" knobs set to "-10" position;
- 4.1.2 Gain- knobs of "CH1 to CH5" on the rear panel anticlockwise set to minimum;
- 4.1.3 Dial switch of "TEL" put out downward. "VOLUME" knob anticlockwise set to minimum;
- 4.1.4 Press power button to "ON" position and indicator light will turn on. Blue means Amplifier is working normally. Red means amplifier is under protection status. (Please check connecting method of output and if mains supply reach the standard.)

### 4.2 "CH1" to "CH5" Operation instruction

4.2.1 Operational instruction is all the same for "CH1" to "CH5". Take "CH2" illustration as an example:

- ① Regulate "BASS" button: to change the low frequency of Tone quality.
- ② Regulate "TREBLE" button: to change the high frequency of Tone quality.
- ③ Regulate "LEVEL" button: to change the input of sound source signal.
- ④ "MUTE" button: indicator light will turn off and amplifier in under normally working statue when you press mute button.
- ⑤ "Z1" to "Z4" button: Each button control one output channel; support signal output and four-channel output at the same time. Press "Z1" to "Z4", Amplifier is on output situation with bright indicator light, amplifier isn't on output situation with dark indicator light. (Button equipped with indicator light).
- ⑥ Regulate "LEVEL" button: to change the output of amplifier signal.
- ⑦ "MON" button: press "MON" button, T-4060MP is on monitor status with bright indicator light. T-4060MP is out of monitor status with dark indicator light.
- ⑧ Indicator light status: Full power delivery when indicator light of -15\ -10\ -5\ 0dB are turn on (Electrical level instruction. Signal input is too heavy to push amplifier in Pressure limit state when indicator light of CLP is turn on (Peak shaving instruction). Amplifier is on protection status without output when indicator light of PROT is turn on (protection instruction).

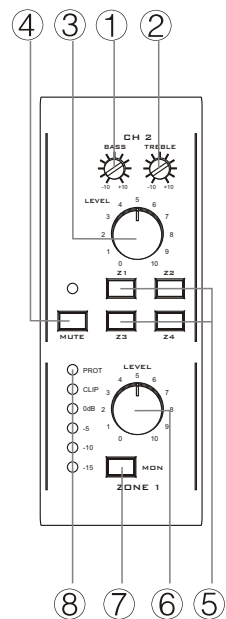

4.2.2 "ZONE1-ZONE4" means amplifier has four independent output channels.

### 4.3 Operation instruction

- ① Regulate "LEVEL" MONITOR: to change the volume output.
- ② Monitor signal output when "-15,-10,-7,-5,-3,0dB" are turn on.
- ③ Power amplifier output four road, actually can only monitor output all the way.

### 4.4 Operation instruction of Remote MIC

"REMOTE MIC INPUT" remote Mic interface: connect to "T-4012 long distance paging Mic" to selection call out and whole zone call out, to control clock and bell; (Input of Remote Mic. own the highest priority when "PRIORITY" is short circuit.)



## OPERATION

### 4.5 Operation instruction of telephone input

4.5.1 "TEL. PAGING" input: all the function button is loss of control function on the front panel, only rare panel is on normal function.

- ① "VOLUME" Regulate the input signal of telephone.
- ② "ZONE" dial switch: four -digit dial switch, each on behalf of one output of amplifier. Dial up means without output of amplifier, dial down means with output of amplifier.

### 4.6 Operation instruction of built-in MP3 Player

4.6.1 Mp3 player can independent startup and shutdown; USB interface, SD card interface "play audio priority automatic".

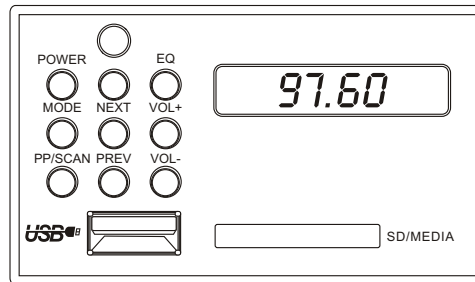

- ① "POWER" button: Press "POWER" button to turn on the power supply, press again to turn off.
- ② "MODE" button: press "MODE" button to mode selection with reception audio or audio presentations mode can be selected.
- ③ "PP/SCAN" button: press "PP/SCAN" radio receiver will automatic search channel.
- ④ "NEXT" button: press "NEXT" move to next page.
- ⑤ "PREV" button: press "PREV" move to previous page.
- ⑥ "EQ" button: press "EQ" button to adjust music frequency.
- ⑦ "VOL +" button: press "VOL+" button to increase the volume.
- ⑧ "VOL -" button: press "VOL-" button to decrease the volume.

### 4.7 RS232 serial port application

Connected to the computer based on the protocol, use software to control the machine's functionality.

### 4.8 CH1, CH2, CH3 switch application

Input switch has three models: LINE, PHANTOM, MIC

- 1) The LINE input was used for audio source input, such as CD, VCD, DVD and other audio equipment.
- 2) The PHANTOM input offer 48V power supply for condenser microphone.
- 3) The MIC input was used for ordinary microphone ,like capacitive microphone.

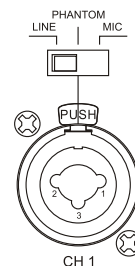

## 5. MUTE FUNCTION

### Instruction of mote priority:

MIC1 has the highest priority in default status: MIC1 highest priority  $\geq$  Telephone  $\geq$  Remote MIC. The priority of MIC1, Telephone, Remote MIC. Can exchange priority through "PRIORITY" terminal short circuit on the rare panel. Remote MIC. has the highest priority  $\geq$  Telephone  $\geq$  MIC1, when "PRIORITY" on short circuit status.

**NOTE:** T-4060MP is equipped with priority exchange terminal "PRIORITY".

## 6. CONNECTIONS

### 6.1 SPEAKER CONNECTIONS

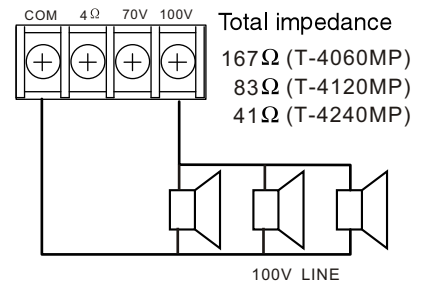
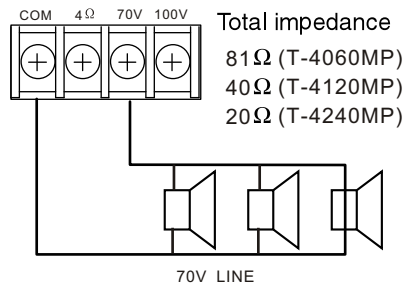
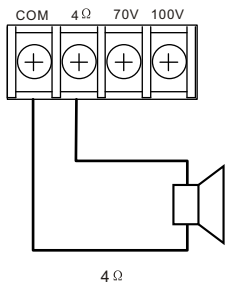

Total impedance  
81 Ω (T-4060MP)  
40 Ω (T-4120MP)  
20 Ω (T-4240MP)

Total impedance  
167 Ω (T-4060MP)  
83 Ω (T-4120MP)  
41 Ω (T-4240MP)

#### Notes

- Both the 4Ω and 70V/100V terminals cannot be used at the same time.
- Impedances indicated in the figures represent the total speaker system (load) impedances.

## WARNING

Be sure to attach the supplied terminal cover after connection completion. Because high voltage is applied to the speaker terminals, never touch these terminals to avoid electric shock.

## 7. TROUBLE SHOOTING

Fault phenomenon	The cause of the problem
There is no sound output when the line connection is good	<ol style="list-style-type: none"> <li>1.No electricity or plug contact undesirable</li> <li>2.The fuse was burn out</li> <li>3.The volume is not open</li> <li>4.No input signal</li> </ol>
Normal startup, the alarm triggered	<ol style="list-style-type: none"> <li>1. Load short circuit or damaged</li> <li>2. Power supply voltage is not stable, too high or too low</li> <li>3. Overload</li> </ol>
In the normal use of all of a sudden no sound output	<ol style="list-style-type: none"> <li>1. Temperature is too high, the machine in temperature protection</li> <li>2. Loose cable connection</li> </ol>

# 8. APPLICATIONS

## REAR PANEL CONNECTIONS

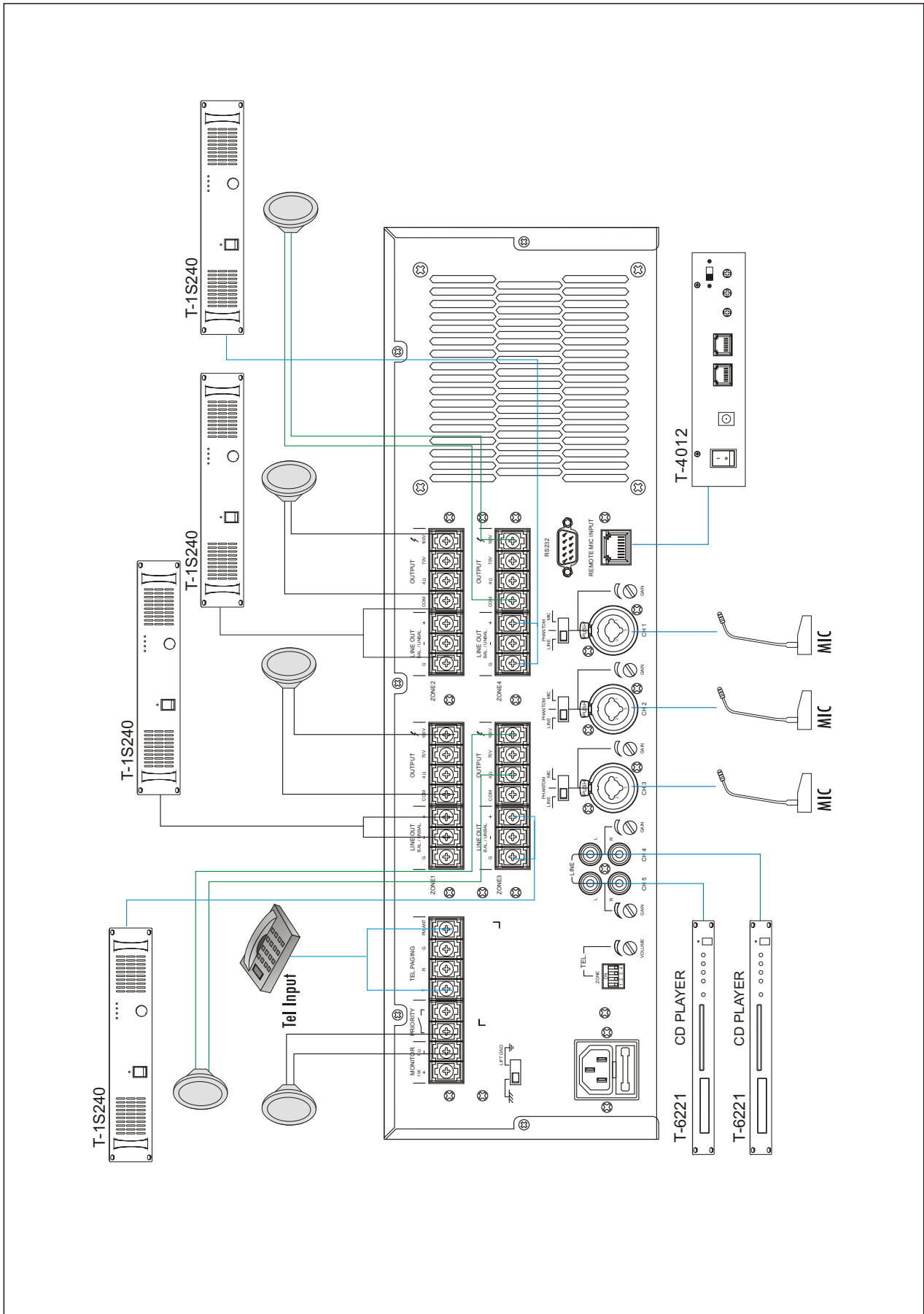



## 10. SPECIFICATIONS

MODEL	T-4060MP	T-4120MP	T-4240MP
POWER OUTPUT	4X60W	4X120W	4X240W
OUTPUT INTERFACE	4R,70V/100V		
MONITOR OUTPUT	1W/8Ω		
INPUT SENSITIVITY AND IMPEDANCE	CH1,CH2,CH3: MIC:±2.5mV/600Ω PHANTOM:±2.5mV LINE:~175mV/10KΩ balance input CH5~6: 350mV/10KΩ balance input TEL: 350mV/10KΩ REMOTE MIC: ±387mV/10KΩ		
TONE	Bass:±10dB at 100Hz Treble:±10dB at 100Hz		
SNR	≥65dB		
LINE1-4 OUTPUT LEVEL	1V/600Ω(balance output)		
FREQUENCY	80-16KHz		
MP3	Support MP3 format, max capacity of 32GB		
SD FILE SYSTEM	Only FAT16, FAT32, the biggest one partition, does not support folder to store		
HARMONIC DISTORTION	≤1%		
COMSUPTION	375W	750W	1500W
SUPPLY VOLTAGE	<input type="checkbox"/> ~110V 50Hz <input type="checkbox"/> ~110V 60Hz <input type="checkbox"/> ~120V 50Hz <input type="checkbox"/> ~120V 60Hz <input type="checkbox"/> ~220V 50Hz <input type="checkbox"/> ~220V 60Hz <input type="checkbox"/> ~230V 50Hz <input type="checkbox"/> ~230V 60Hz <input type="checkbox"/> ~240V 50Hz <input type="checkbox"/> ~240V 60Hz		
DIMENSION	484X440X132mm		
NET WEIGHT	8.1Kg	11.68Kg	22Kg
GROSS WEIGHT	9.36Kg	13.48Kg	24Kg

# 11. DIMENSIONAL DIAGRAM

UNIT :mm

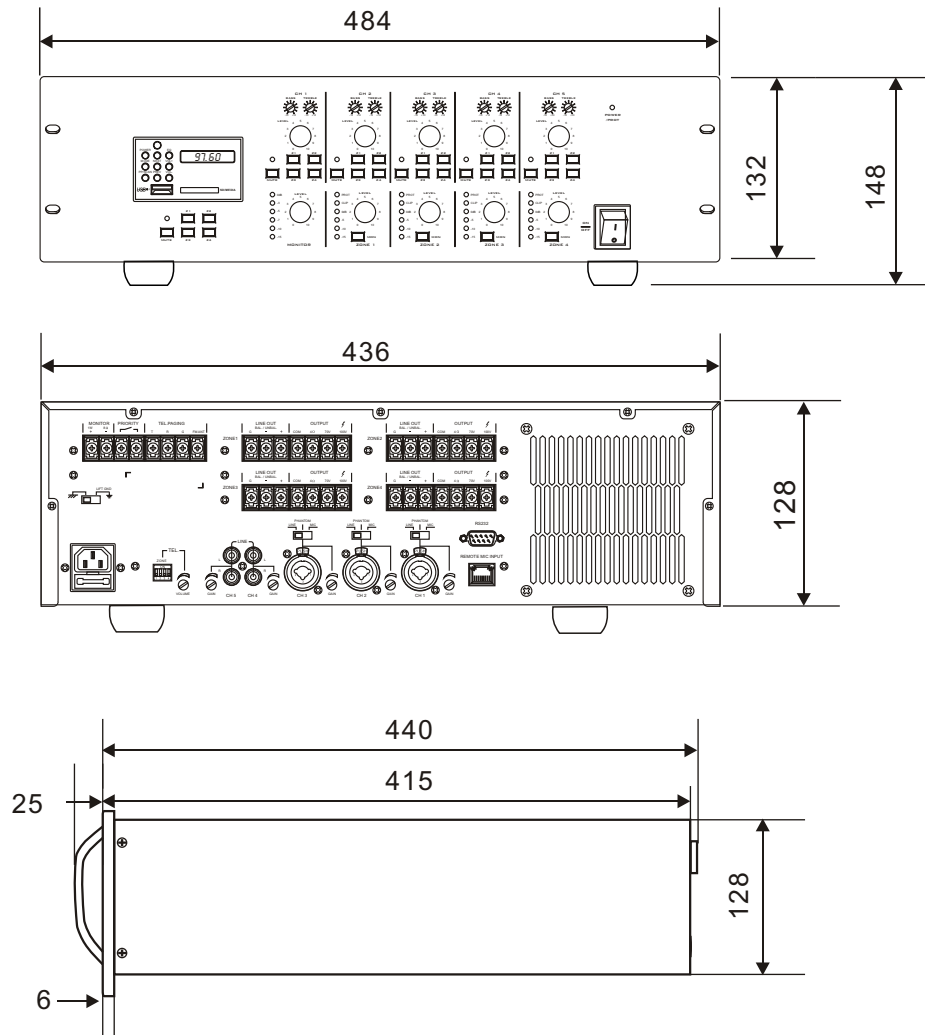

Keep the unit's all sides over 10 cm away from objects that may obstruct air flow to prevent the unit's internal temperature rise.

UNIT :mm

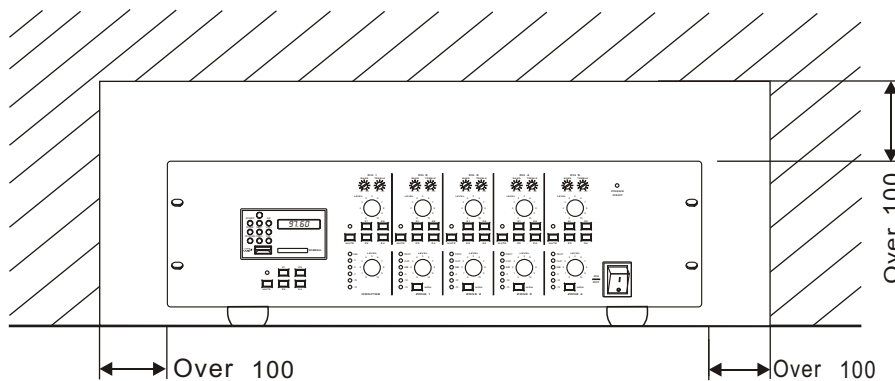

# PUBLIC ADDRESS SYSTEM

